

Designing and analysis of solar-powered electric vehicles

Praveen Kumar Sharma Principal Siddhi Vinayak Polytechnic College Alwar .

Ms. Anjana Tiwari , Assistant Professor LIET College Alwar

Abstract: The emission of greenhouse gasses from transportation vehicles is one of the most alarming environmental threats and the emission of these gases is mounting at a distressing pace. Limited fossil fuel resources are also a threat to the automobile industry. This work aims to describe the solar-powered electric vehicle (SPEV) as the key to solving the downside of fuel and pollution. A battery is used in an electric vehicle (EV) which is charged from both external power supply and also from photovoltaic (PV) panels which absorb radiation from the sunlight and generate electrical power. A maximum power point tracker (MPPT) controller is employed to track the utmost power. A buck- Boost converter is utilized to amplify the DC voltage procured from the photovoltaic module and then the boosted output is transmitted to a three- phase voltage source inverter (VSI). VSI is used to transform the solar DC voltage to AC voltage and feeds the brushless direct current (BLDC) motor which controls vehicle applications.

KEYWORDS: Brushless DC motor Buck-boost converter, Maximum power tracker Perturb and observe, Renewable energy, Solar-powered electric vehicle

1. INTRODUCTION

Present world transports are completely dependent on combustion engines which power the vehicle causing serious threat to the environment by emission of green gas emission. Even though, there are many changes in the world transport technology from compound fuels to electric vehicles (EVs). Because of high cost and electric vehicle accuracy, many people doubt the new technologies in transportation. Sun is the main energy source for solar-powered electric vehicles (SPEVs). Zero pollution is possible with SPEVs. SPEVs main advantages are they take energy from the sun, to recycle the energy regenerative braking system is utilized and mechanical losses are less, zero-emission, easy infix, control, and fault critical due to higher energy efficiency . The utilization of EVs personally is very less and their status in the market is not up to the mark because these are needed to be charged for every 60-70 km drive. At present many electric vehicles are getting charged through roadside charging units, and parking stations. Generally, it takes approximately 2 to 3 hours to recharge the battery in EV and also varies with the battery capacity. It is the main point that is affecting the EVs from usage. The problem is solved in reference by introducing a new mechanism in which the system charges the battery system automatically.

A large number of researches have been done for the improvement of PV system efficiency, different approaches are employed for the tracking of maximum power point from PV module for solving the efficiency problems and many products with these procedures are available in market for consumers. Solar power is the most efficient and practical alternative source of renewable energy. The SPEVs are far away from physical world feasibility because of their cost, energy shortcomings, and low power density. In EVs and PHEVs, the batteries are usually made of many battery cells which are connected either in series or in parallel. Different operating conditions and variations caused during manufacturing imbalances reduce usable energy

2. Research Method

This paper deals with the charging of electric vehicles using renewable energy. The workflow diagram of the presented methodology explains about working of SPEV. Figure 1 depicts various steps involved in the proposed methodology

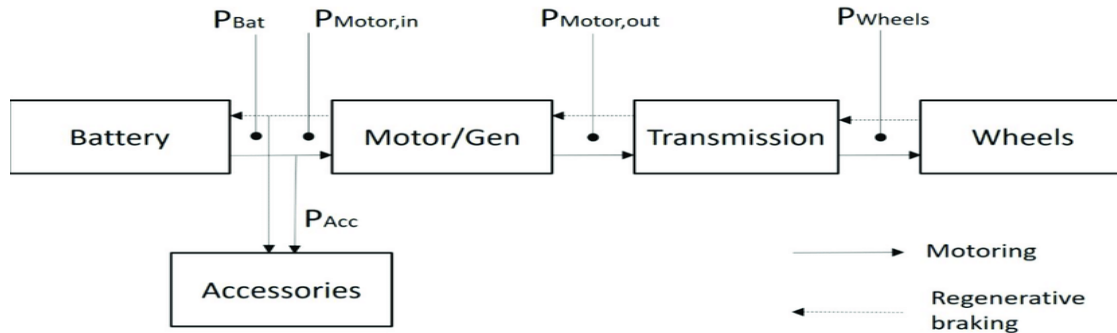

Figure 1. Workflow diagram of the proposed methodology

2.1 Solar Cell

The solar cell is commonly known as a photovoltaic (PV) cell. electrical component that transforms solar radiation into electrical power by the combination biochemical and physical phenomenon. Its characteristics like current and voltage will get effected when exposed to solar radiation. The building blocks of PV modules are also known panels. A PV panel is a combination of numerous solar cells attached in both parallel. One photovoltaic cell can be designed using a source, a diode, and two resistor shown in Figure 2 For mathematical modeling of the photo voltaic cell, basic equation derived from the commensurate circuit of the photovoltaic cell shown in Figure 2 .

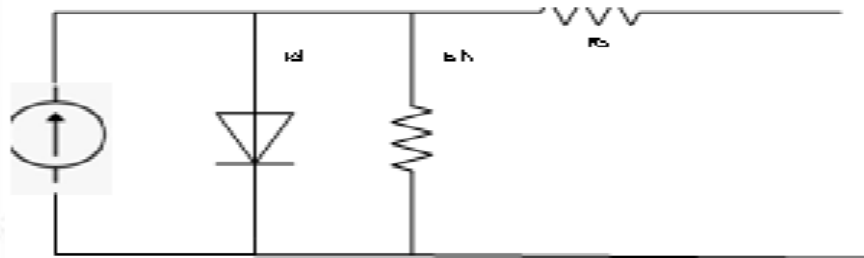

Figure 2. Equivalent circuit of the solar cell

The current generated from the solar cell can be given by (1) [25]–[27].

$$I_{pv} = I_{sh} - I_d = I_{sh} - I_0 (e^{(V+I.R_s) / (kTc)} - 1) \quad (1)$$

Where V is voltage inflicted across the cell, Q is the charge of an electron, A is the idealizing aspect, Tc is the temperature of the cell, K is the Boltzmann’s constant, and I_0 is dark saturation current. Short circuit current (I_{sc}) is generated when the voltage across the cell zero and is the highest generated current during a short circuit. Its mathematical equation is given by (2) .

$$V_{open\ circuit} = Vt \ln(I_{sh} I_0) \quad (2)$$

Where $Vt = akTc$. Figure 3 shows a PV module simulation in which a constant irradiance of 1000 W/m² is fed to the solar cell using a PS constant block. The output power, voltage, current data from the solar cell is exported to the workspace using the “To Workspace” block, and I-V, P-V characteristics are plotted.

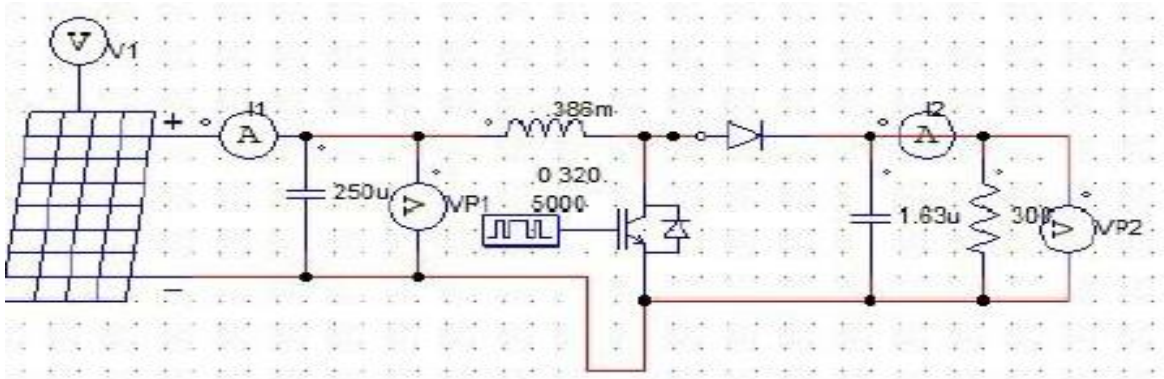

Figure 3. Simulation of PV module

2.2 Maximum power point tracking (MPPT)

MPPT is a device that tracks the maximum power from the PV module and switches it into voltage and provides maximum current for the battery to charge. For present MPPT’s conversion is 93-93% efficient. The usual power gain we get in summer is 10-15% whereas; we get 20 to 45% power gain during winter. However, the actual power gain depends on man factors like heat and the state of charge of the battery. So, a P&O algorithm is used in MPPT to get thighest power from PV panels for running the load. Figure 4 shows the P&O algorithm of MPPT. The P&O works on the principle of changing the voltage levels by comparing the previous power with recent power

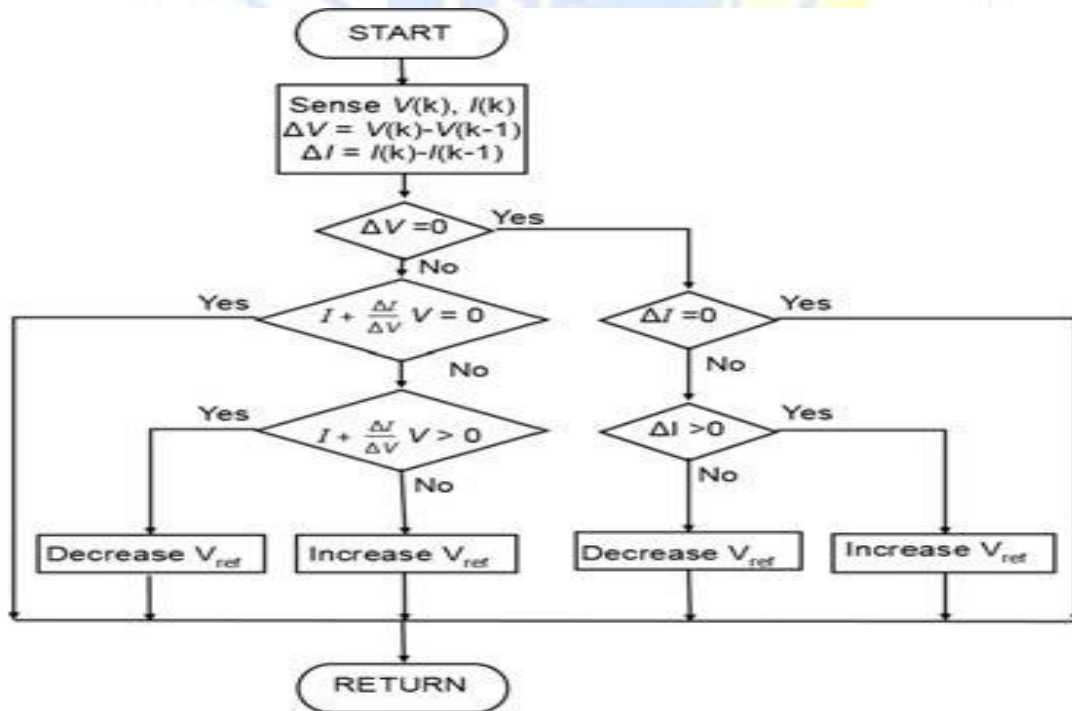

Figure 4 . MPPT algorithm

2.3 Buck-boost converter

A buck-boost converter is well defined as a DC-DC converter that transforms the input DC voltage by enhancing or diminishing it. The amplitude of the output voltage from this converter depends on the factor, the duty cycle]. It can be initiated in either the continuous or the discontinuous conduction mode. In the former conduction mode, the current coursing within the inductor tolerably emancipates but does not reach zero before the commencement of the switching cycle. On the other hand, In the latter conduction mode, the current within the inductor becomes zero. When the circuit is triggered, the current starts flowing from the input source to the inductor and load. While the circuit is turned off, the inductor skims current through the diode to load continuously. The capacitor at the output end reduces the ripples in output. Figure 5 shows the circuit diagram of the buck-boost converter. A voltage source is given as input to the circuit. MOSFET acts as one switch and diode acts as another switch. The diode is connected in opposite to the power flow direction from the input source and capacitor and the load is connected in parallel

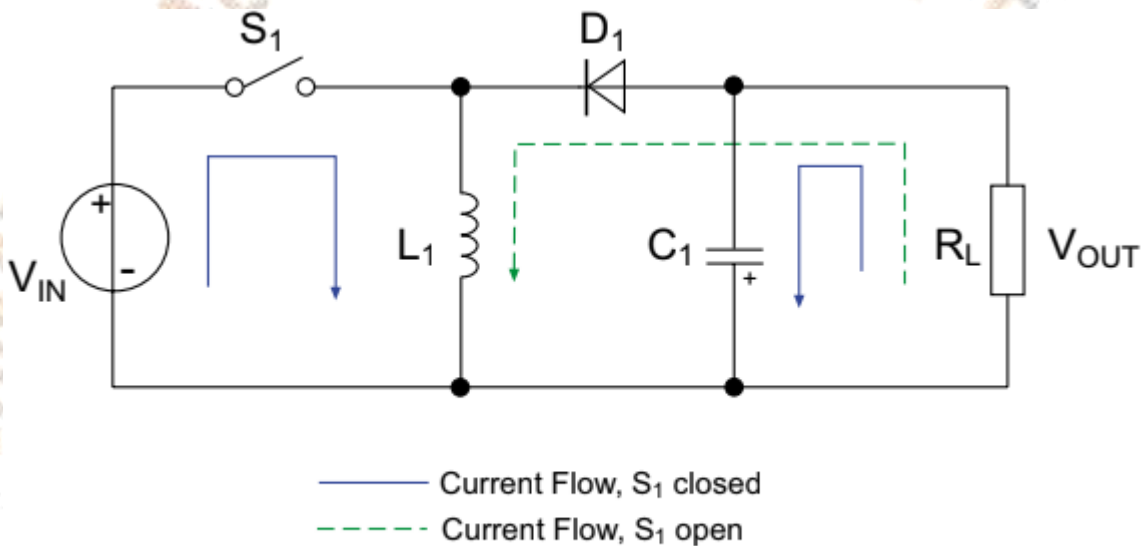

Figure 5. Buck-boost converter

2.4 Charge controller

It is a device that helps us to protect the battery from getting overcharged. The charge controller uses switched series regulator for PV applications to control the charging current. PWM is the most commonly used control method. With the same frequency but with differ in duty ratio power supply is given to the battery . This method is the same as buck converter but the difference is here it is a PV Power source whose current is little. The control algorithm depends upon the battery type used and most of the charge controllers provide numerous settings to accommodate different voltages.

2.5 Battery

Lead–acid battery having a very low energy-to weight ratio and a low energy-to-volume ratio, its ability to supply high surge currents means that the cells have a relatively large power-to-weight ratio. These features, along with their low cost, make it attractive for use in motor vehicles to provide the high current required by automobile starter motors

2.6 Voltage Source Inverter

The circuit produces an AC voltage from a DC voltage source. The DC voltage is fed to the inverter. For the simulation of voltage source inverter (VSI), insulated gate bipolar transistors (IGBTs) with individual pulse generators are used. To limit the higher-order harmonics LC filter is used with the inductance of value 1.4 H and capacitance of value 50 μF

2.7 Brushless DC motor

This motor converts supplied electrical into mechanical energy. There are distant types of motors which are can be used, but among those, BLDC has high efficiency and easy to control, less weight, simple construction, and can also be used in various applications. The BLDC motor has the advantage of power-saving when compared to other motors. In this motor, the magnetic fields of the rotor and stator are with related frequency. BLDC motors have more lifetime and efficiency as this motor has no brushes. It also has more starting torque and fewer losses. Three-phase BLDC motors are more widely used in electric vehicles

3. RESULTS AND DISCUSSION

In this research paper, the simulations have been performed using MATLAB. Figure 6 (a) depicts the I-V characteristics of the single photovoltaic cell and Figure 6 (b) depicts the P-V characteristics of the single photovoltaic cell. A temperature of 25 °C and irradiance of 1000 W/m² are recorded while the characteristics were obtained. The output of photovoltaic cells decreases with the change in intensity of light incident on the solar cell and it also changes with an increase in solar cells which causes a change of solar cell parameters

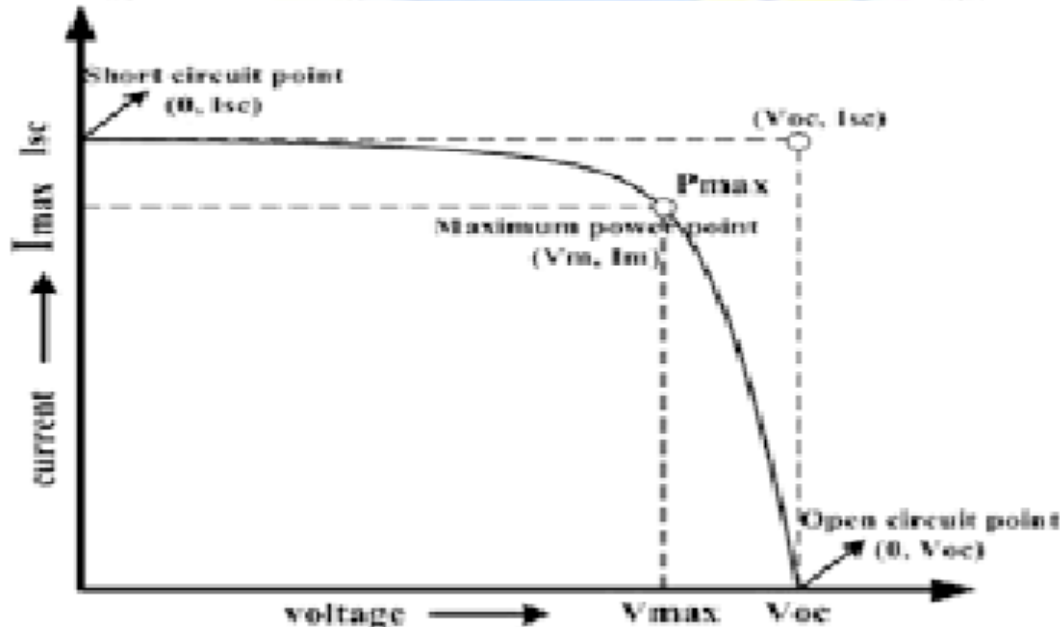

Figure 6. Characteristics of the solar cell for (a) I-V

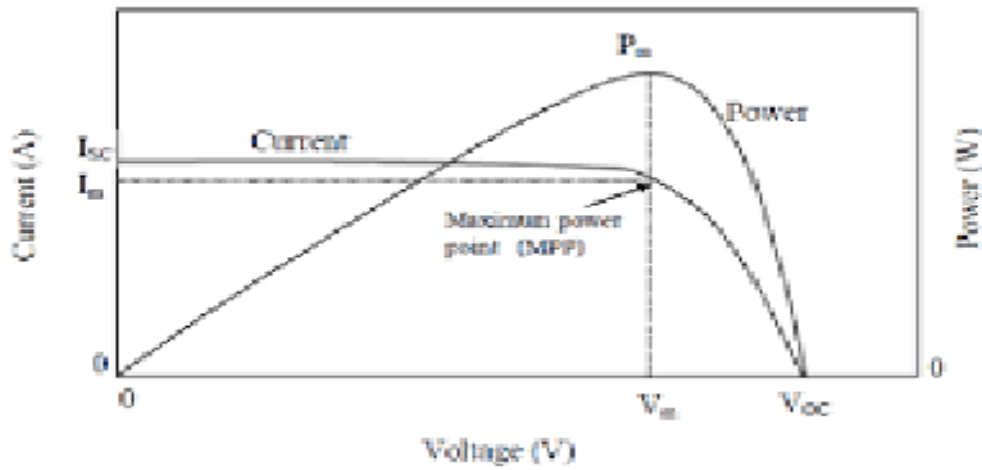

Figure 6. Characteristics of the solar cell for (b) pv

Figure 7 shows the output of 3 phases VSI which is sinusoidal by using L-filter. Generally, the output of VSI is of square shape which is full of harmonics. If it is fed to the BLDC motor it leads to damage to the motor. So, LC filter is required to limit the harmonics and get a sinusoidal output. Figure 8 shows the current and voltage outputs of the Photovoltaic module in which the irradianations are changed from 0 to 1000 for various time instances and at a temperature of 25 °C. The output voltage from the PV panel is above 60 V which is boosted by a buck-boost converter to feed the battery for charging. Figure 9 shows the voltage and current output waveforms of the buck-boost converter whose input is given from a PV array for various irradianations and at a constant temperature of 25 °C. One can observe the output voltage coming out of the buck-boost converter is approximately 120 V which is almost double the output voltage of the Photovoltaic module which means here the buck-boost converter acted as a boost circuit

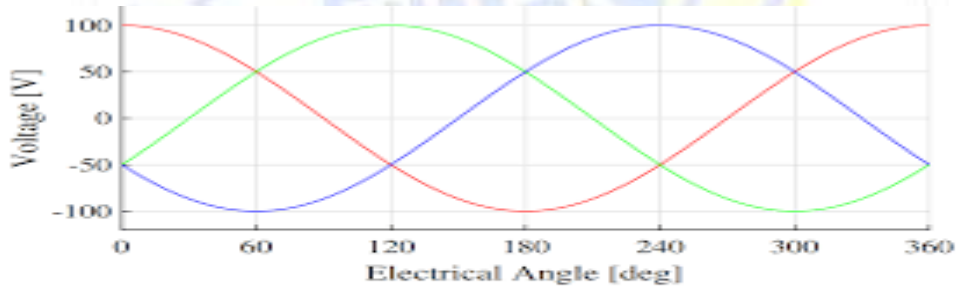

Fig 7. The output waveform of 3 phase VSI

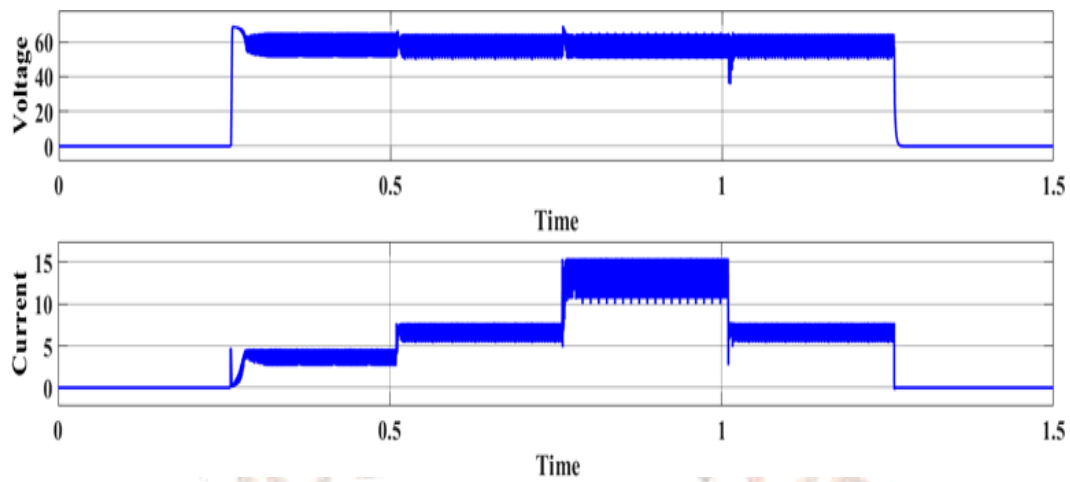

Figure 8. The output of the PV panel

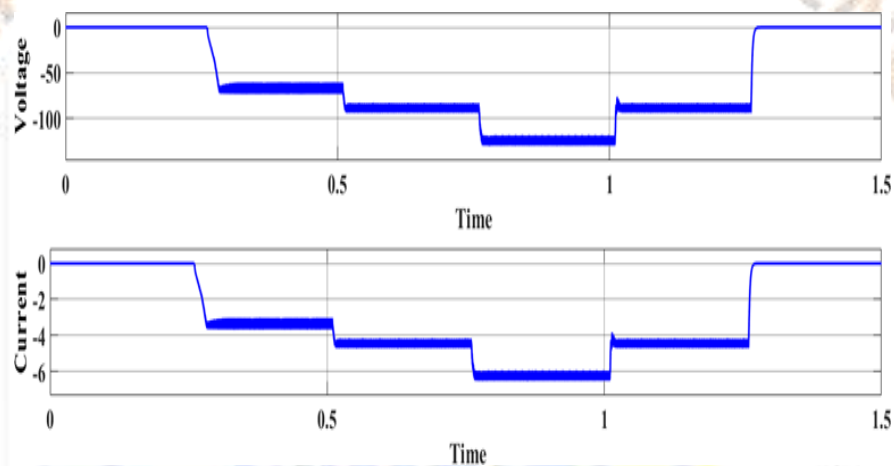

Figure 9. The output of the buck-boost converter

4. CONCLUSION

This paper represents the usage of renewable energy resources for the reduction of the effect of greenhouse gases on the environment caused by combustion engines. PV panels are used for the generation of electricity in solar-powered electric vehicles (SPEVs). Completely depending on solar power also have some disadvantages like limited range, high initial cost. But these can be avoided by conducting further research in this area and also by using ultra-efficient solar cells which give 30-35% efficiency.

5. Reference

1. T. L. Gibson and N. A. Kelly, "Solar photovoltaic charging of lithium-ion batteries," *Journal of Power Sources*, vol. 195, no. 12, pp. 3928-3932, Jun. 2010, do. 10.1016/j.jpowsour.2009.12.082.
2. M. Pahlevaninezhad, D. Hamza, and P. K. Jain, "An improved layout strategy for common-mode EMI suppression applicable to high-frequency planar transformers in high-power DC/DC converters used for electric vehicles," *IEEE Transactions on Power Electronics*, vol. 29, no. 3, pp. 1211-1228, 2014, do: 10.1109/TPEL.2013.2260176
3. D. P. Mishra, S. Chakraborty, and T. K. Taripathy, "Voltage Regulation of PV Cell using PID Controller," *International Conference on Recent Innovations in Electrical, Electronics & Communication Engineering (ICRIEECE)*, 2018, pp. 206-211, do: 10.1109/ICRIEECE44171.2018.9008536

4. B. Pakkiraiah and G. D. Sukumar, "Research Survey on Various MPPT Performance Issues to Improve the Solar PV System Efficiency," *Journal of Solar Energy*, vol. 2016, doi: 10.1155/2016/8012432
5. Praveen Kumar Sharma, Ms. Anjana Tiwari "Research A STUDY ON ELECTRIC VEHICLES CHARGING SYSTEM UTILIZING WITH SOLAR ENERGY" *Journal of International Journal for Multidisciplinary Research* , Volume 5, Issue 5, September-October 2023
6. M. Caspar, T. Eiler, and S. Hohmann, "Comparison of active battery balancing systems," *Proc. IEEE Vehicle Power Propuls. Conf. (VPPC)*, pp. 1-8, Oct. 2014, doi: 10.1109/VPPC.2014.7007027
7. Praveen Kumar Sharma , Ms.Anjana Tiwari "ELECTRICAL VEHICLE : A NOVEL APPROACH TO DEVELOPING A SOLAR-POWERED ELECTRICVEHICLES CHARGING SYSTEM UTILIZING VEHICLE -TO - GRID-ENABLED SMART TECHNOLOGY" *International Journal of Research and Analytical Reviews – IJRAR*. Volume 10 | Issue 3 | September 2023.
8. G. J. Osório *et al.*, "Rooftop photovoltaic parking lots to support electric vehicles charging: A comprehensive survey," *International Journal of Electrical Power & Energy Systems*, vol. 133, 2021, do: 10.1016/j.ijepes.2021.107274

