

Design And Development Of Advance Railway Track Crack Detection System Using Iot

Prof. Gaurav Nagdevte¹, Ganesh Malode², Himanshu Ambulkar³, Jatin Dongre⁴, Navneet Punde⁵, Sneha Meshram⁶, Reshma Thaware⁷

¹Project Guide, Department Mechanical Engineering, Abha Gaikwad Patil College Of Engineering, Nagpur
²³⁴⁵⁶⁷Students, Department Mechanical Engineering, Abha Gaikwad Patil College Of Engineering, Nagpur

Abstract-

In India rail transport is at the forefront of providing the transport infrastructure wanted to meet the desires of a rapidly growing economy. Today, India has the fourth largest railway network in the world. However, in phrases of reliability and safety standards, we have not but reached international standards indeed. The largest problem regarding railway analysis is locating cracks in the structure. If left unmanaged, they can be left astray and lose the proper path. The proposed gadget is suitable for rail transport to discover cracks in the tracks in advance and to prevent accidents. In this paper to use the crack sensor, this will be installed on the train engine. With this, if a certain crack is found on the track the train starts to slow down and stop somewhere automatically and the exact location of the crack will be given to the control room. Secondly the following cause of accidents is prevented from two trains facing the same lane the use of the same sensors installed on the engine, while the sensor hears the same signal from another train and automatically applies the brakes and stops the train at a certain distance. A train diversion causes use of several losses in train accidents.

Keywords —*crack detection, railway, IR sensor, IOT module, Arduino Controller etc.*

1. Introduction

Due to the rapid development of rail structures, excessive-speed trains are being used and rail transport is increasing day via day. Most people use the railway for transportation, freight and passenger transport from one place to another. The railway line provides services such as excessive speed, low cost, friendly environment. these features can be done during maintenance and control sessions. however depending on the factors, deterioration and damage may occur in the upper railway building. those deviations and other problems with the rail device such as poor maintenance, current railway monitoring faults from staff. Such flexibility and deterioration are timely and safety measures are very important to the safety of rail systems.

Therefore, the solution to this problem we present in this project. To provide protection from rail damage due to cracks occurring in the track. This device is used among two channels to detect current cracking on the track the use of IR sensors that transmit sine waves through the ideal track. If a crack is detected, then this sensor will send a signal to the Arduino Uno board which will activate the IoT module. The IoT module will specify the exact location to which the message will be sent to the authorities. live feeds and data from the IoT module will be updated on the meant use of the wireless device. through using this technology, we will be able to prevent the loss of valuable existence or property.

2. Problem Statement

Broken train speaks of one of the world's leading causes of costly and dangerous rail accidents. Considering the common occurrence, all of which are thought of in our own right, each three days there is more than one major demolition, continuously over 10

years. Accessible interventions in which cross-country fracture conflicts are disrupted do not help enough to understand the political, social and environmental consequences. In the current frame, whilst the track is unlocked, the frame is forced to go

out and align the track at unusual intervals. Normally, it will send a exclusive flag to the specialising using the remote control module in case something stands out from the line. Separation is detected via IR sensors and the error flag is transmitted.



Figure 1. Railway Track Crack

• Train accident statistics

Figure 2 shows the variety of deaths due to train accidents. As can be seen in determine 2, the death toll increases each year. There is therefore a great need for a technical solution to the problem of train cracks.

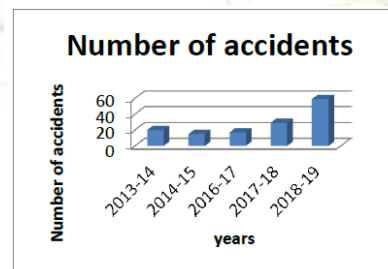

Figure 2. Number Of deaths year wise

3. Objective

The main objective is to discover gaps in the railway line and to decide whether there are any accidents on the tracks in order to avoid identity and prevent accidents. This type of model provides a cost-effective solution to the problem of railway

detection by means of the usage of an ultrasonic sensor and IR sensor joint that responds to the precise position of the faulty track, as well as transmitting information to the IOT control room, so that abig apple incidents can be closed.

4. Existing System

In the present machine, techniques such as visual inspection, video transmission, and magnetic area techniques can detect cracks in the railroad tracks. Physical examination is one of the first steps in which all the necessary parts will be scanned with the aid of hand. This procedure is commonly used in India, despite producing a very bad result. The camera is used to monitor the tracok while the content is being broadcast. In this process small cracks and a more expensive machine cannot be detected. The current passes through the railway line to detect errors in the current eddy path and the output outcomes are inaccurate. Manew york of these methods require a lot of processing power and a very long time, which makes the robot speed slow and uncomfortable.



Figure 3. Manual crack detection by human

5. Proposed Methodology

5.1. Block Diagram

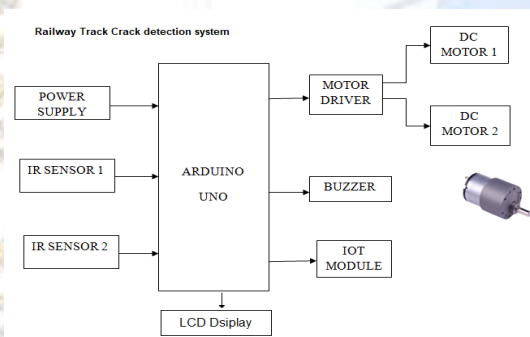

Figure 4. Block Diagram

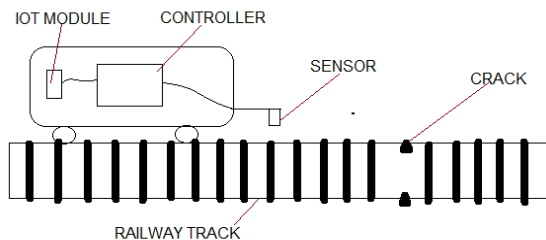

Figure 5. Structural Diagram

5.2. Working

In our task, there are sets of IR sensors mounted on both facets of the vehicle. This unit is used to show on / off the GSM transmitter unit within the event of a crack in the track.

The IR Transmitter and the IR receiver circuit are used to discover cracks. it's far suited to the the front of the automobile with the best layout.

A. At Normal Condition

An IR transmitter sensor transmits infrared radiation with the help of a 555 IC timer circuit. those infrared radiation is detected via an IR receiver sensor. Transistors are used as a part of the amplifier. beneath normal circumstances the Transistor isn't OFF. At that point the transmission is CLOSED, in order that the car can move continuously.

B. At Crack Condition

In instances of break up transmission IR transmitter and IR receiver, resistance for all opportunity and receiver is high because of non-stop IR waves. consequently the output of the transistor from the OFF role to the ON level. At that factor the relay ON role. At that factor, the engine electricity deliver is disconnected and transformed to IoT unit. The IoT module is centered on the nearest station manager, in order that the alarm sign is given to the station supervisor.

5.3. Components and Description

The principle additives of the automatic crack track check car are:

- IR sensor
- Arduino
- IoT unit
- Motor motive force
- liquid crystal display show
- D.C. Motor
- Wheels
- Railway
- Battery.

A. IR Sensor

In our project the IR transmitter and receiver circuit are used to discover the crack of the train tune. two pairs of sensors are used.

Sensor 1: One aspect of the educate tune
 Sensor 2: the opposite facet of the educate song
 Sensor 1 and a pair of sensors are used to hit upon cracks inside the train tune and to provide control signal to the GSM transmission unit.

B. Arduino

Arduino is an open source computer and software organization, assignment and community of users who design and convey single-board microcontrollers and a microcontroller kit to construct a digital device and interactive talents that can make sense and manage gadgets in the digital international.

Forums geared up with sets of digital and analog input / output pins that can be related to various extension forums and other regions.

Forums comprise a chain of communication links, which encompass familiar Serial Bus in some models, and are also used to download applications from personal computers.

Microcontrollers are usually programmed using unique capabilities from programming languages C and C++. traditional examples of such devices for novices consist of interests, thermostats, and motion detectors.

C. IOT Module

The internet of factors (IoT) is making changes and enhancing the manner we work and live. however, it's miles best possible with complete IoT solutions built on flexible wi-fi connectivity and longevity. Crack statistics is sent to a licensed man or woman the use of IoT.

D. Motor Driver

Drivers function a visual hyperlink among engines and manage circuits. Motor calls for a excessive modern-day fee even as the manage location operates at low modern signals. it's miles therefore the task of motorists to take a low present day manage signal and convert it right into a high cutting-edge signal that can drive the engine.

E. D.C. Motor

In our mission a permanent DC motor is used. An electric powered motor is a gadget that converts electrical strength into mechanical electricity. Its action is primarily based on the precept that after the incumbent driver is now positioned in a magnetic field, he receives a magnetic area whose route is given via Fleming's left hand rule. when the engine is running, it improves torque. This torque can produce gadget rotation. DC vehicles are also much like turbines divided into shunt wound or collection wounds or included motor motors.

when the strength input is high, the related driver is enabled. As a end result, the output is active and operational in stages and inputs. in addition, while the strength enter is low, that driving force is disabled, and its output is closed and in a country of excessive interference.

F. Frame

The frame is made p with MS steel materials. The visible device includes a battery, a automobile tire device.

G. Railway Track

The railway line is made of M.S.metallic material. The middle of the wheel is V-grooved, so that the car can circulate in a straight line.

H. Battery

substances: Lead-Acid Output Battery: 12 V
Output energy: 7 Ampere-Hour.

6. Calculation

1. **Selection of electric motor**

- A) 30 RPM DC motor SPEED = 30
- B) RPM VOLTAGE = 12 VOLT
- C) WATTS = 18 WATT

2. **Torque of the motor**

- A) Torque = (P X 60) / (2 X 3.14 X N)
- B) Torque = (18X 60) / (2 X 3.14 X 30)
- C) Torque = 5.72 Nm Torque = 5.72 x 10³ N-m
- D) The shaft is made of MS and its allowable shear stress = 42 MPa

- E) Torque = 3.14 x fs x d³ / 16 5.72 x 10³ = 3.14 x 42 x d³ / 16 D = 8.85 mm
- F) The nearest standard size is d = 9 mm.

3. **Electrical (electric) power equation**

- A) Power P = I x V Where V = 12 W = 18 I=18/12=1.5
- B) A H.P = .02414

4. **Battery calculation**

- A) BAH /CI = 8 ah/420ma = 19 hrs
- B) To find the Current Watt = 18 w
- C) Volt = 12v Current =?
- P= V x I 18 =12 x I I = 18/12 = 1.5
- D) AMPS battery usage with 1.5 AMPS
- BAH /I 8/1.5 = 5.3 hrs.

7. CAD Design

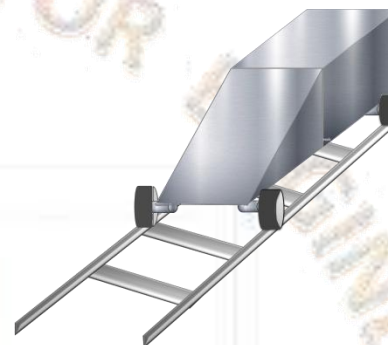

Figure. 6. Cad design

8. Results and Discussion

The project "robot that detects teach track cracks" was designed in any such way that it designed the set up device with out using an IoT module. The project unveiled the vehicle area straight away after the discovery of a crack in the railway line and in the course of the discovery of boundaries. The device permits localization of acquisition the use of a base station network through Io module alerts and transfers vicinity to a small controller the controller assumes the area switch feature the usage of Io module resources.

- The controller video display units the situations supplied and acts according with the code.
- The controller enables the driver to operate and the engines to move at the music.
- Then IoT is activated and sends the message to close by stations.
- Sensors are activated and could always locate cracks or obstacles.
- If a crack is detected, the robotic displays the message "cracked".
- After the message is displayed the robot stops walking on the track.

The subsequent parent suggests the Crack Detected or impediment found on the Arduino show display screen,

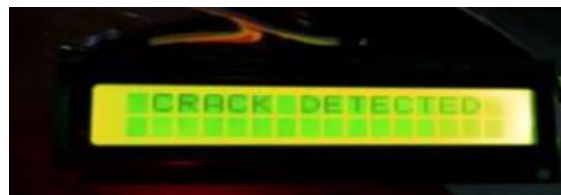



Figure.8. i) Crack Detected ii) Obstacle Detected

The following figure shows that SMS received on cellular telephones are inside the latitudinal and longitudinal areas where a crack or impediment is located.

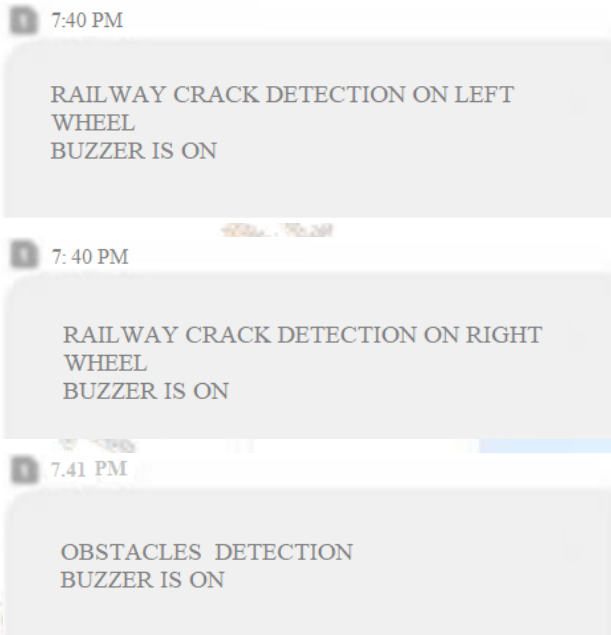

Figure.9. Information Received in the mobile Phone

The proposed device introduces IoT-primarily based era, to prevent train injuries. An IoT module with a sensor tool hooked up at every quit of the train. whilst the teach starts off the tune, the signal breaks and a notification is given to the engine driving force and an emergency brake is applied. the main cause of the paintings is to avoid train accidents with out manual electricity.

9. Advantage

1. Very green and friendly layout for the individual.
2. espy to use.
3. Low power consumption.
4. The location of the auto may be decided the usage of GPS.
5. Stumbling cracks use of IR impediment sensors
6. GPS tracking information based on GPS and GSM to send SMS
7. keep away from the risks of single music.
8. a hit shape.
9. Works worldwide (GSM availability).

10. Application

1. It is miles which might be used in railway offerings to reduce accidents.

11. Conclusion

The proposed Arduino-based totally detecting machine is primarily able to come across cracks in rails, in addition to small cracks without human intervention. The proposed system has many more blessings than conventional visible techniques. benefits include quicker availability and reporting facilities, decrease fees, lower electricity intake and plenty less testing time. similarly, the clean availability of additives and simplicity of vision makes the proposed system lots better to use on a large scale with little or no initial aid. As a result, it may draw efficiently and successfully underneath running situations. With this proposed version, we will avoid accidents due to road cracks, which helps us to keep extra lives.

On this venture, we've designed a low-powered board and excessive-efficiency board that permits for excessive levels of rail safety to keep the teach from harm. and railway obstacles. The prototype looking model of the teach can without problems find cracks and obstacles in track. The effects show that these new technology will increase the reliability of the safety device in educate transport. through the use of these functions in actual-time software, we have been capable of save you crashes in approximately 70%.

References

- [1] Selvamraju Somalraju, Vigneshwar Murali, Gourav Saha, Dr.V.Vaidehi, "Robust Railway Crack Detection Scheme (RRCDS) Using LEDLDR Assembly," IEEE Int. Conf. on Networking, Sensing and Control, vol. 6, iss. 3, pg. 453-460 , May2012.
- [2] Qiao Jian-hua; Li Lin-sheng; Zhang Jing-gang; "Design of Rail Surface Crack- detecting System Based on Linear CCD Sensor," IEEE Int. Conf. on Networking, Sensing and Control, vol. 14, no. 4, pp. 961-970, April 2008.
- [3] K. Vijayakumar, S.R. Wylie, J. D. Cullen, C.C. Wright, A.I. Shammaa, " Non invasive rail track detection system using Microwave sensor," Journal of App. Phy., vol. 9, iss. 11, pg. 1743- 1749, June 2009.
- [4] Reenu George , Divya Jose, Gokul T G , Keerthana Sunil , Varun A G," Automatic Broken Track Detection Using IR Transmitter and Receiver", International Journal of Advanced Research in Electrical, Electronics and Instrumentation Engineering (IJAREEIE), Volume 4, Issue 4, April 2015.
- [5] Prof. P.Navaraja, "CRACK DETECTION SYSTEM FOR RAILWAY TRACK BY USING ULTRASONIC AND PIR SENSOR", International Journal of Advanced Information and Communication Technology (IJAICT) ,Volume -1, Issue-1, May 2014
- [6] Akhil n, Dinumohan , Fayis p, Sijagopinath," Railway Crack Detection System", International Research Journal of Engineering and Technology (IRJET) ,Volume: 03 Issue: 05 | May-2016
- [7] Rajesh Iv, Manjunathgasuti, Mukundaswamy," CRACK DETECTION AND COLLISION AVOIDANCE IN RAILWAY TRACKS" IRF International Conference,Volume 2,12th June, 2016.
- [8] Saurabh Srivastava , Ravi Prakash Chaurasia , Syed Imran Abbas , Prashant Sharma, Nitin Kumar Singh," Railway Track Crack Detection Vehicle" International Advanced Research Journal in Science, Engineering and Technology(IARJSET), Vol. 4, Issue 2, February 2017.

- [9] Ajeya G R, Ashwini N, Kavitha S, Latha D C, Chaithra G, "Robust Railway Track Crack Detection Scheme", International Research Journal of Engineering and Technology (IRJET), Volume: 03 Issue: 05 | May-2016
- [10] S. Arivazhagan, R. Newlin Shebiah, J. Salome Magdalene and G. Sushmitha, "Railway Track Derailment Inspection System Using Segmentation Based Fractal Texture Analysis" Ict Academy Of Tamilnadu (Ictact) Journal On Image And Video Processing, August 2015, Volume:06, Issue: 01.

