

Enhancing Power Quality With Reduced Harmonic Distortion Using Zeta Converter

R. Ganesh Dr. R. Azhagumurugan,

ABSTRACT

With the increase in the usage level of solar energy all across the world, it is necessary to deliver a better output with reduced losses. Conventional PV systems seem to be an efficient solution to the environment but energy conversion efficiency is still low. The purpose of this system is to enhance the output power quality with mitigated total harmonic distortion developed due to non-linear loads. The proposed system consists of PV system connected to the non-linear load through Zeta converter using fuzzy logic controller. The DC power from the PV panel is boosted using Zeta converter which provides suitable output with reduced losses. A DC capacitor connected across VSI acts as a series hybrid active power filter (SHAF) to reduce harmonics and compensates reactive power.

This system is simulated using MATLAB/SIMULINK. The performance is analysed and compared with conventional PV system which uses DC-DC boost converter. Zeta converter with FLC provides better harmonic compensation, low ripple voltage and higher output than boost converter with FLC. The result is compared in terms of its input, output and THD. It is concluded that the proposed technique provides improved power quality.

Keywords: Total harmonic distortion, FLC, PV Panel, Harmonic compensation, MATLAB, SIMULINK.

I. INTRODUCTION

In today's smart grid era, the large number of applications of various power electronic devices and the access of distributed power sources and energy storage devices make power quality problems increasingly prominent and complex. Therefore, in the era of smart grid, enhancement of power quality is of great significance. Power quality refers to the quality of various indicators of electrical energy. Ideally, the public grid signal should be a sine wave with constant amplitude and frequency, and when three-phase AC is used, the voltage and current amplitudes of the phases are required to be the same, while the phase symmetry is 120° . In reality, this ideal state does not exist because of the effects of generators, transformers, and various non-linear loads, or other external disturbances and power failures.

The Reliability and Quality are two important aspects of any electrical power supply system. Power Reliability means availability of power supply 24 x 7 basis which constitutes adequacy of electrical system at all levels from generation, transmission to distribution. However, power quality refers to both the extent of deviation or distortion in pure supply waveform and the continuity of supply. When quality of the power supplied is deficient, it results in performance degradation and reduced life expectancy of an equipment. Therefore, we may understand poor power quality as any power problem manifested in voltage, current, or frequency deviations that result in failure, increased energy loss or malfunctioning of an equipment, thus causing economic loss. Poor power quality can also result in problems with electromagnetic compatibility and noise. 2

In the emerging surplus power scenario, the characteristics of loads and the requirements of electrical systems have changed significantly. The devices and equipment used presently in industrial, commercial and domestic facilities are more sensitive to supply variations than equipment used in the past. It is due to increased use of power electronics and microprocessor-based technologies in equipment and appliances. The increasing penetration of Renewable sources of energy, semiconductor based electronic equipment, non-linear loads, data centres, industries running on adjustable speed drives and arc furnaces, etc. distort voltage/current waveforms in non-conformity to their desired form. This brings challenges to maintain the quality of power to ideal one and ensuring efficacy.

Poor power quality not only causes performance degradation and premature failure of electrical equipment but also results in increased system losses, financial loss etc. Therefore, apart from the reliability i.e. continuous supply, the preference of the electricity consumers is now shifting towards quality power supply from the distribution licensees. Optimum power quality can enhance productivity and reduce losses.

II. OBJECTIVE

I. To enhance the Power Quality.

II. To reduce Total Harmonic Distortion.

III. To eliminate the issues related to Power Quality and Voltage Regulations.

IV. To increase the response of the system whenever three phase symmetrical faults occurs.

III. Purpose of work

The proposed is to provide better power by reducing its harmonics and increasing its quality. Three phase fault is compensated by this network and hence rated voltage flows across the network. Thereby power quality is improved. In order to increase power quality, enhanced components must be used. The fuzzy logic controller (FLC) has surpassing advantage than PI controller and also fuzzy algorithm aids to track maximum power from the PV module. This provides desired outputs even though fault occurs. The comparative analysis of improved function abilities and its drawbacks of proposed convertors are designed to adjudge which of these convertors is pertinent in order to substantiate optimal convertor.

IV. Conventional System

• In a regular power system,

1. **Electric power** is produced in the generators,
2. Transformed to an appropriate voltage level in the transformers,
3. Sent out via transmission lines for final distribution to the load.
4. Whenever fault occurs in the transmission line between grid and non-linear load it may lead to power quality issues.
5. In order to compensate that voltage, grid is connected to PV system via Boost converter and this output is given to an inverter which converts constant DC output to an AC output in order to connect them to the main utility grid via step up transformer to synchronize the voltage level to that of the grid voltage.

V. Proposed System

- The proposed system consists of **PV system connected to the non-linear load through Zeta converter using fuzzy logic controller.**
 - To increase the transient response and power quality,
1. An existing DC-DC boost converter is replaced zeta converter.
 2. The DC power from the PV panel is boosted using Zeta Converter which provides suitable output with reduced loss.

3. A DC capacitor connected across VSI, acts as a series Hybrid Active Power Filter to reduce harmonics and compensates reactive power.

- The purpose of this system is to enhance the output power quality with mitigated Total Harmonic Distortion developed due to non-linear loads.
- This system is simulated using MATLAB/SIMULINK.

VI.Design parameters of PV Module

Short circuit current I_{sc} of each cell = 7.34 A

Open circuit voltage V_{oc} of each cell = 0.6 V

Irradiance = 1000 W/m²

Quality Factor = 1.5

No of Solar Cells = 12

No. of series connected modules per string = 6

No. of parallel strings = 2

Total voltage of the panel = 12 V

Temperature of the panel = 25o C

VII.SIMULATION OF GRID INTERACTIVE PV SYSTEM

The proposed and existing systems are implemented MATLAB/SIMULINK. The simulated results are compared in terms of its improved function abilities to adjudge which of these converters is pertinent in order to substantiate optimal system. The overall simulation is illustrated in this chapter and each block is explained correspondingly. The below block diagram shows the flow of working in Simulink model.

Block Diagram

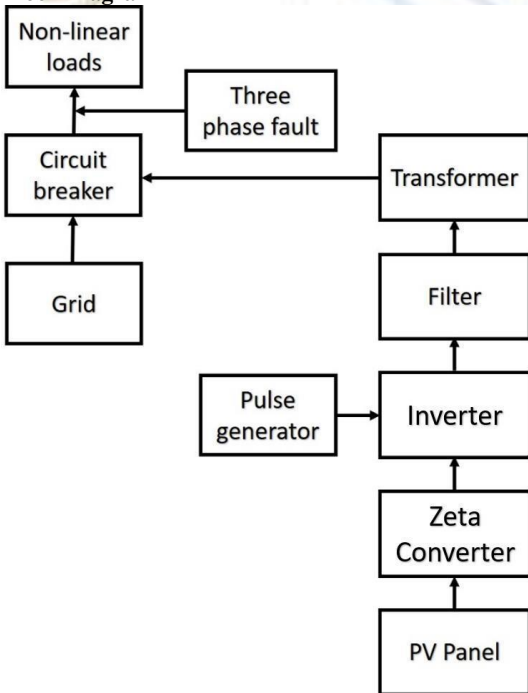

VIII.Result analysis

- Simulations are implemented using MATLAB SIMULINK and the results are taken correspondingly.
- Comparison analysis is totally based on its output characteristics such as total harmonic distortion and compensation of sag voltage of both the converters.
- The result which were taken from both the systems are compared, in accordance with source voltage, voltage to be injected, Compensated voltage and total harmonic distortion.
- According to the result analysis, we can conclude which system is providing a better performance by increasing its power quality and providing faster response to the fault.

SOURCE VOLTAGE

SOURCE VOLTAGE WITH FAULT OF EXISTING SYSTEM

SOURCE VOLTAGE WITH FAULT OF PROPOSED SYSTEM

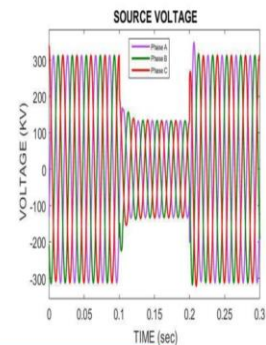
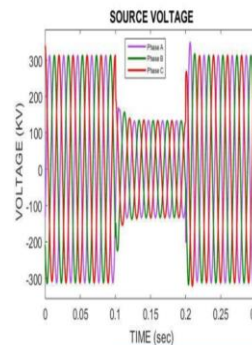

From 0 sec to 0.1 sec, the voltage flow is normal. The three phase fault is applied at non-linear loads from 0.1 to 0.3secs

VOLTAGE TO BE INJECTED

VOLTAGE TO BE INJECTED IN EXISTING SYSTEM

VOLTAGE TO BE INJECTED IN PROPOSED SYSTEM

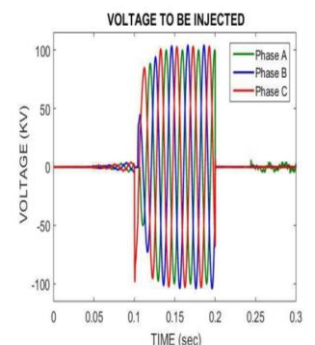
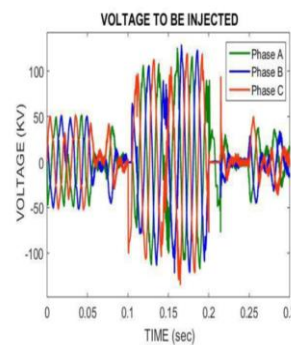

- It is observed whenever fault occurs the reduced voltage is generated by the designed circuit.
- This amount of voltage is injected to the source voltage during the fault.

COMPENSATED VOLTAGE

Sum of source voltage and amount of voltage injected.

COMPENSATED VOLTAGE OF EXISTING SYSTEM

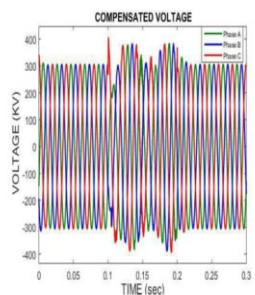

COMPENSATED VOLTAGE OF PROPOSED SYSTEM

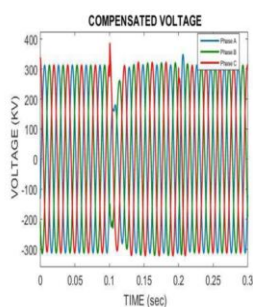

In DC-DC boost converter, the magnitude of compensated voltage is closer to rated voltage whereas in zeta converter the result is accurate. So, as a result either the fault occurs or not, the magnitude remains constant. After 0.3 sec the fault is cleared, the voltage is same that was earlier.

THD ANALYSIS

THD ANALYSIS OF EXISTING SYSTEM

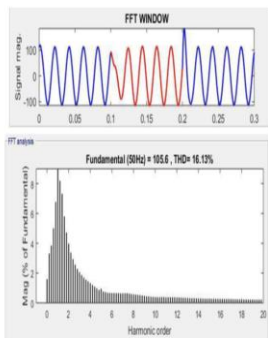

THD ANALYSIS OF PROPOSED SYSTEM

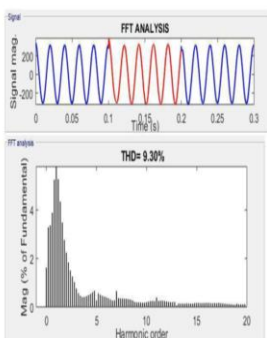

THD of existing system 16.13% is higher than the THD of proposed system 9.30%.

IX. Conclusion

- Using Zeta converter, the *response of the system is increased* whenever three phase symmetrical faults occur and also provide *better compensation than normal DC-DC boost converter*.
- Instability due to power quality issues were mitigated before demand occurs in the system.
- The reliability and power quality will be improved drastically if the proposed concept is implemented in large scale.
- The load either linear or non-linear, whenever the three phase fault happens, the voltage gets compensated faster.
- The harmonics developed during compensation is mitigated with this proposed technique.
- The proposed technique also acts as **automatic voltage regulator**.
- It is observed that **THD value of zeta converter is significantly less**. Hence, the **steady state value is obtained in a short duration**.
- This may conclude that *zeta converter performs better than the existing DC-DC boost converter on mitigating harmonics and enhancing the power quality*.

X. Scope of work

In future, the proposed technique also response to the unsymmetrical faults and provide improved power quality and also increase its stability by advanced algorithms.

XI. References

- Prakash K. Ray, Soumya Ranjan Das, and Asit Mohanty, (2019) 'Fuzzy Controller Designed PV based Custom Power Device for Power Quality Enhancement', Vol.: 34, Issue: 1, pp. 405 – 409.
- Saptarshi Rakshit ; Jayabrata Maity, (2018)'Three Phase,10 kVA Dual Conversion type Automatic AC Voltage Regulator - An Approach based on Fuzzy Logic Controlled Cuk converter and PI controller Three Phase Inverter'.
- Muhammad Salman, Abdul Basit, Muhammad Shoaib Khalid, Affaq Qamar, (2018) 'Reduction in Total Harmonic Distortion of Cascaded H-Bridge Multilevel Inverter with Using Phase Method'.
- Atsushi Nakajima, Shigeo Masukawa, (2018) 'Study of Boost type DC-DC Converter for Single Solar Cell', IECON.
- Mohamed S. Zaky and Mohamed K. Metwaly, (2017) 'A Performance Investigation of a Four-Switch Three- Phase Inverter-Fed IM Drives at Low Speeds Using Fuzzy Logic and PI Controllers', Vol.32 , Issue: 5 ,pp. 3741 – 3753.
- Ahana Malhotra, Prerna Gaur, Shitiz Vij, Charvi Malhotra,(2016) 'Design, analysis and performance of zeta converter in renewable energy systems'.
- Soedibyo, Budi Amri, Mochamad Ashari, (2015) 'The comparative study of Buck-boost, Cuk, Sepic and Zeta converters for maximum power point tracking photovoltaic using P&O method'.
- Ammar Hussein Mutlag, H. Shareef, A. Mohamed,(2014) 'Power quality enhancement in autonomous PV system using fuzzy logic controller'.
- Ritu Sharma , Alka Singh , A.N. Jha, (2014) ' Performance evaluation of tuned PI controller for power quality enhancement for linear and non-linear loads'.
- Hussain S. Athab, P. K. Shadhu Khan, (2007) 'A Cost Effective Method of Reducing Total Harmonic Distortion (THD) in Single-Phase Boost Rectifier'.